

# 600 Channel with Q-Flow Ductile Iron Rail Spec Sheet

## Two Meter Channel

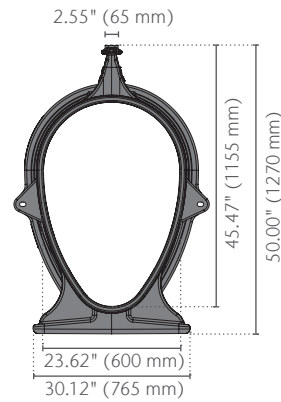

## Closing End Plate

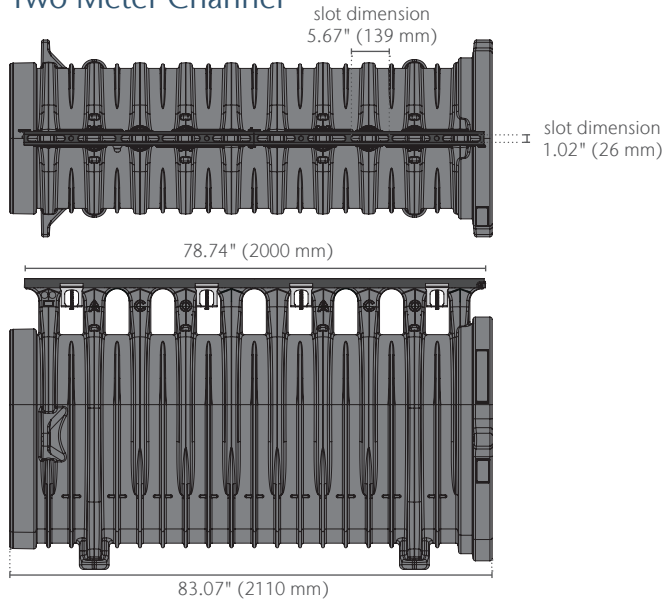
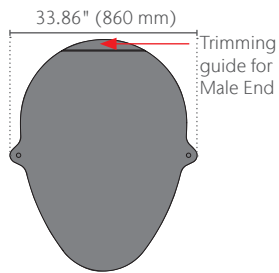

## Closing End Cap

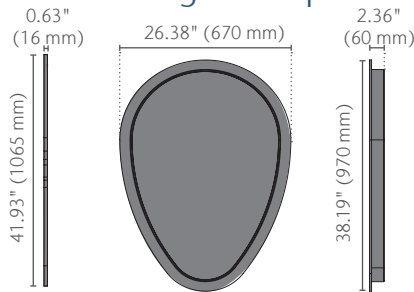

## Outlet Flume/Catch Basin Connectors

### Male

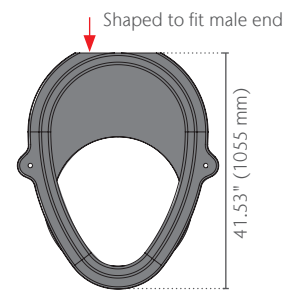
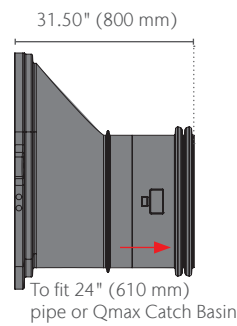

## Typical Qmax 600 Connection to Catch Basin

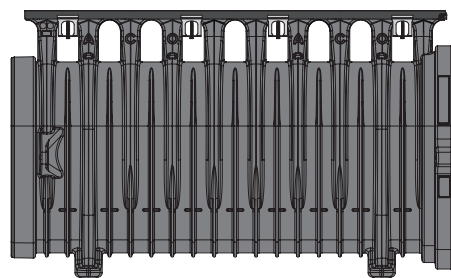

Qmax 600 Channel

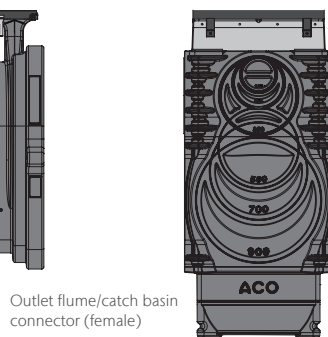

Outlet flume/catch basin connector (female)

Qmax Catch Basin(Tall)  
-see appropriate Spec info

### Female

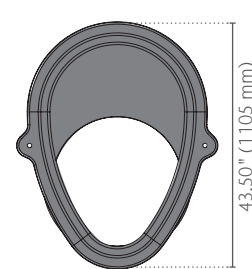

31.50" (800 mm)

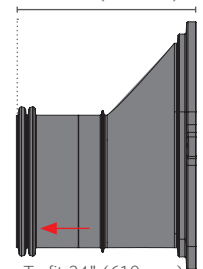

To fit 24" (610 mm) pipe or Qmax Catch Basin



# 600 Channel with Q-Flow Ductile Iron Rail Spec Sheet



Product Name	Part No.	Invert Depth in (mm)	Weight lbs
Qmax 600 Channel with Q-Flow Ductile Iron Rail - 78.75" (2000 mm)	<b>32840</b>	45.47 (1155)	143.7
<b>Accessories</b>			
Qmax 600 Closing end plate (Fits male/female end of uncut channels)	<b>32845</b>	-	21.6
Qmax 600 Closing end cap (Easy push fit cap for cut channel ends)	<b>32888</b>	-	10.8
Qmax 600 Outlet flume/catch basin connector (male)	<b>44364</b>	-	27.1
Qmax 600 Outlet flume/catch basin connector (female)	<b>44365</b>	-	27.5

## Specification Summary

### General

The surface drainage system shall be ACO Qmax 600 with Ductile Iron Q-Flow top as manufactured by ACO, Inc. or equal approved.

### Grates

Grates shall be factory fitted to MDPE bodies to provide a monolithic unit. Water intake area per 2 meter unit will be 58.20 in<sup>2</sup> (37,550 mm<sup>2</sup>)

### Catch Basin

See appropriate spec info for catch basin information.

### Installation

The trench drain system shall be installed in accordance with the manufacturer's installation instructions and recommendations.

### Materials

The trench system bodies shall be manufactured from medium density polyethylene with:

- Compressive strength: 8,450 psi
- Flexural strength: 2,224 psi
- Water absorption 0.31%

The nominal clear opening shall be 23.62" (600 mm) with unit overall width of 33.86" (860 mm). Units shall be manufactured with a neutral invert of 45.47" (1155 mm). Each unit will feature a full radius in the channel bottom and a male to female interconnecting end profile, a rubber seal shall be fitted to the bell end of the channel unit. Units shall have molded anchoring features on the outside wall to ensure maximum mechanical bond to the surrounding bedding material and pavement surface.



EN1433 Load Class F  
202,328 lbs – 4,177 psi

## ACO, Inc.

© January 2026 ACO, Inc.

All reasonable care has been taken in compiling the information in this document. All recommendations and suggestions on the use of ACO products are made without guarantee since the conditions of use are beyond the control of the company. It is the customer's responsibility to ensure that each product is fit for its intended purpose and that the actual conditions of use are suitable. ACO, Inc. reserves the right to change products and specifications without notice.

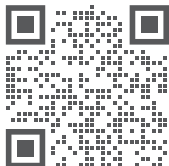

info@acousa.com  
www.acousa.com

